

Copying of this document, and giving it to others and the use or communication of the contents thereof, are forbidden without express authority. Offenders are liable to the payment of damages. All rights are reserved in the event of the grant of a patent or the registration of a utility model or design.

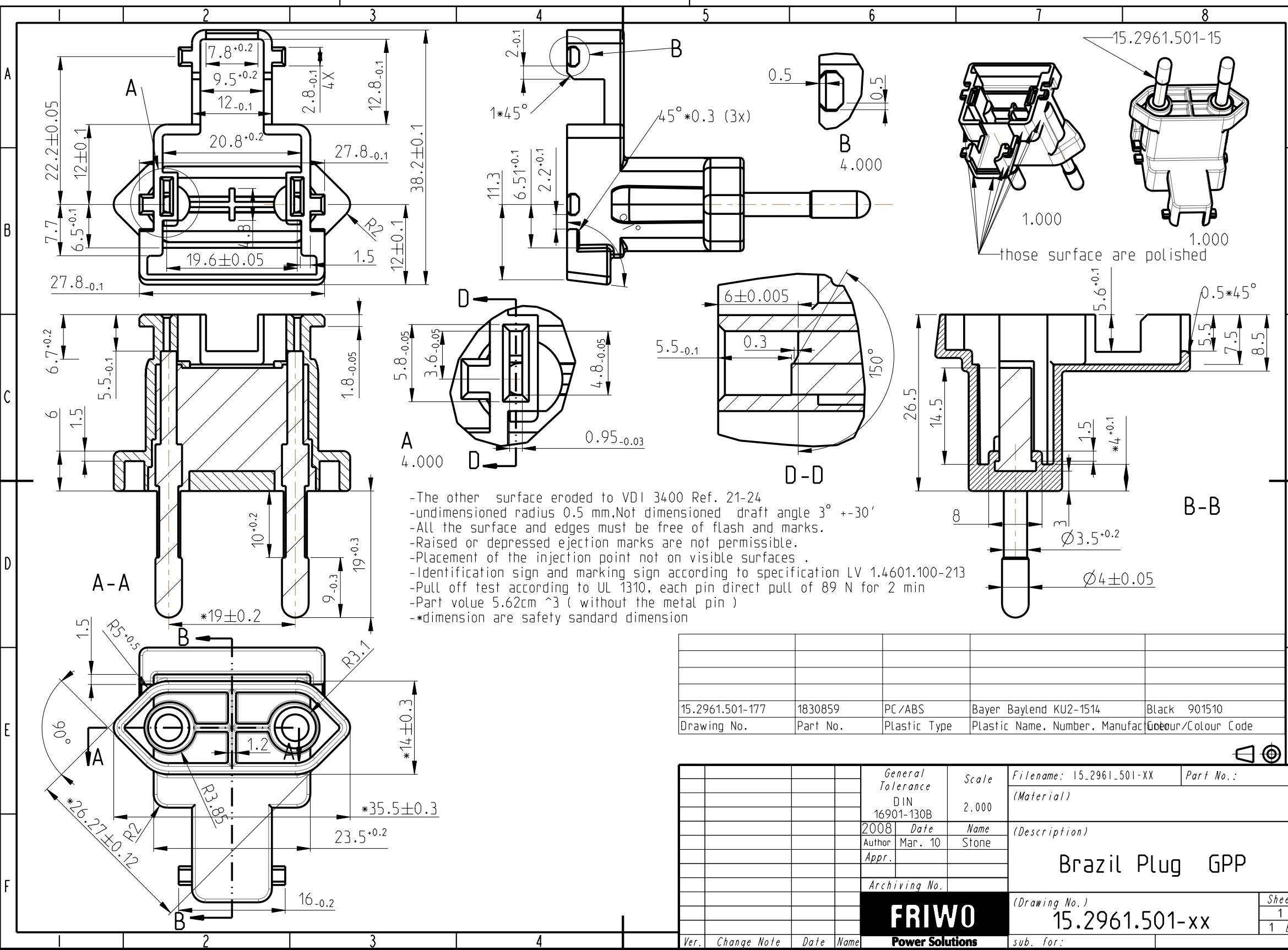

- The other surface eroded to VDI 3400 Ref. 21-24
- undimensioned radius 0.5 mm, Not dimensioned draft angle 3° +-30'
- All the surface and edges must be free of flash and marks.
- Raised or depressed ejection marks are not permissible.
- Placement of the injection point not on visible surfaces.
- Identification sign and marking sign according to specification LV 1.4601.100-213
- Pull off test according to UL 1310, each pin direct pull of 89 N for 2 min
- Part value 5.62cm³ (without the metal pin)
- *dimension are safety standard dimension

15.2961.501-177	1830859	PC/ABS	Bayer Baylend KU2-1514	Black 901510
Drawing No.	Part No.	Plastic Type	Plastic Name, Number, Manufact	Colour/Colour Code

General Tolerance DIN 16901-130B		Scale 2.000	Filename: 15.2961.501-XX	Part No.:
2008	Date	Name	(Material)	
Author	Mar. 10	Stone	(Description)	
Appr.			Brazil Plug GPP	
Archiving No.			(Drawing No.)	Sheet
			15.2961.501-xx	1
Ver.	Change Note	Date	Name	1 Bl.
			FRIWO	
			Power Solutions	
			sub. for:	